



www.gotowti.com

An ISO 9001 Certified Company



Wireless Technology, Inc.

Sidewinder High Definition IP Cameras

SW720-H.264-HD

Installation and Operation Manual

Including:

Optional X30 Optical Zoom (HD30)

Optional Electric Brakes (ENG)

Optional Nitrogen Pressurization (P)

Optional Connector Interfaces (HV)(AMP)

120VAC and 24VAC Options

TABLE OF CONTENTS

INFORMATION	3
<i>FCC NOTICE</i>	3
READ THIS MANUAL	3
PRODUCT WARRANTY AND REPAIR	4
PRODUCT WARRANTY	4
REPAIR AUTHORIZATION	5
RETURNS	5
WARNING	6
SAFEGUARDS	7
GENERAL DESCRIPTION	8
MODELS AND FEATURES	9
INSTALLATION	10
RECOMMENDED TOOLS FOR PROPER INSTALLATION	10
INSTALLATION PLANNING	10
DIMENSIONS AND MOUNTING	11
MECHANICAL DIMENSIONS	11
MOUNTING	12
MOUNTING ACCESSORIES	13
120VAC MS SIGNAL CONNECTIONS	19
24 VAC MS STYLE SIGNAL CONNECTIONS	20
120VAC AMP STYLE SIGNAL CONNECTIONS	21
SIGNAL DESCRIPTIONS	22
120VAC LINE CONNECTIONS	22
24VAC POWER CONNECTIONS	22
ETHERNET SIGNAL CONNECTIONS	22
ANALOG VIDEO CONNECTIONS	22
HARD WIRED PTZ SERIAL CONTROL PORT	22
RJ-45 SERIAL DATA BREAKOUT BOX	23
CAMERA ETHERNET PROTOCOLS AND PORTS	23
CAMERA ETHERNET PROTOCOLS AND PORTS	24
DEFAULT IP ADDRESS	24
DEFAULT PORT ADDRESSES	24
CAMERA PROTOCOL SUPPORT	25
SURGE PROTECTION AND PRESSURIZATION	26
SEALING AND PRESSURIZATION	26
SPECIFICATIONS	27
X30 ZOOM IMAGE SENSOR AND LENS	27
X20 ZOOM IMAGE SENSOR AND LENS	27
VIDEO ENCODING	28
CAMERA HOUSING MODULE	28
PAN AND TILT DRIVE ASSEMBLIES	29
ELECTRICAL	30
ENVIRONMENTAL	30
MECHANICAL	31
REVISION HISTORY	31

INFORMATION

FCC NOTICE

This device complies with Part 15 of the FCC Rules.

Operation is subject to the following two conditions:

- 1.) This device may not cause harmful interference.
- 2.) This device must accept any interference that may be received, including interference that may cause undesired operation.

READ THIS MANUAL

Every effort has been made to insure that this WTI system is of the highest quality. This product has been carefully inspected to comply with rigid quality standards before shipment to you. In consideration of your investment and the desire to obtain full performance capability engineered into your new WTI product, we recommend that you read this manual before attempting to operate your system.

FOR MORE ASSISTANCE OR MORE INFORMATION

WTI (Wireless Technology, Inc.)
2064 Eastman Avenue, Suite 113
Ventura, CA 93003-7787

TOLL FREE. 866/gotowti (468-6984)
TEL. 805/339-9696
FAX. 805/339-0932

EMAIL: sales@gotowti.com

INTERNET: <http://www.gotowti.com>

The software / firmware furnished with the equipment is confidential to and is copyrighted by *Wireless Technology, Inc. (WTI)*. It is not to be copied or disclosed in any manner without the consent of *Wireless Technology, Inc. (WTI)*. The software/firmware is furnished to the purchaser under a license for use on a single system.

Information furnished by *Wireless Technology, Inc. (WTI)* is believed to be accurate and reliable. However, no responsibility is assumed by *Wireless Technology, Inc. (WTI)* for its use or for any infringements of other rights of third parties, which may result from its use. No license is granted by implications or otherwise under any patent or patent rights of *Wireless Technology, Inc. (WTI)*

©2011 Wireless Technology, Inc. (WTI)
All rights reserved.

PRODUCT WARRANTY AND REPAIR

PRODUCT WARRANTY

We appreciate your purchase of *Wireless Technology, Inc. (WTI)* security products. We take pride in the quality of our products and have manufactured each new WTI product to exacting quality standards. In normal use, it will provide you with years of satisfactory performance. However, should you experience difficulty; you are protected under the provisions of this warranty.

WTI warrants to the original user a product that is free of defects in materials and workmanship in normal use. WTI warrants to the original user that WTI's products will be free of defects in materials and workmanship in normal use for a period of 24 months from the date of sale. WTI's obligation under this warranty shall be limited to the repair, including all necessary parts and the cost of labor connected therewith, or at our option, the replacement of any product that shows evidence of a manufacturing defect within the warranty period. This warranty is extended to all WTI products purchased and used within the United States of America and is valid only when service is rendered by the authorized WTI (*Wireless Technology, Inc.*) Warranty Station.

This warranty shall not apply to appearance or accessory items including, but not limited to, knobs, connectors, cabinets and connecting cables. This warranty shall not, in addition, apply to repairs or replacements necessitated by any cause beyond the control of WTI including, but not limited to, acts of nature, improper installation, misuse, lack of proper maintenance, accident, voltage fluctuations, unauthorized repairs or modifications.

This warranty becomes void in the event serial numbers are altered, defaced or removed, or an attempt is made to field service or alter performance of any WTI products.

WTI reserves the right to make changes in design, or to make additions to, or improvements upon, products without incurring any obligation to install the same on products previously manufactured.

The foregoing is in lieu of all other warranties expressed or implied and WTI neither assumes nor authorizes any person to assume for it any other obligation or liability in connection with the sale of our products. In no event shall WTI or its Authorized Dealers be liable for special or consequential damage arising from the use of this product, or any delay in the performance of this warranty due to causes beyond its control.

PRODUCT WARRANTY AND REPAIR

REPAIR AUTHORIZATION

Please contact *Wireless Technology, Inc. (WTI)*, to obtain a repair authorization number (RA) and provide the following information:

- 1.) Product Model & Serial Numbers
- 2.) Date of shipment, purchase order number, sales order number or WTI invoice number.
- 3.) Details of the defect or malfunction. If there is a dispute regarding the warranty or product, which does not fall under the warranty conditions stated within the description of the written warranty, please include a written explanation with the product when returned.

SHIP FREIGHT PRE-PAID TO:

WTI (Wireless Technology, Inc.)
2064 Eastman Avenue, Suite 113
Ventura, CA 93003-7787
TEL 805/339-9696
FAX 805/339-0932

RETURNS

No unauthorized returns will be accepted. All returns must have an authorized (RA) number issued by the factory (CA number if returned for credit and RA number if returned for repair). Products returned for repair or credit will be rejected if no authorization number has been issued or freight has not been pre-paid. All merchandise returned for credit will be subject to a 20% restocking and refurbishing charge.

PRODUCT WARRANTY AND REPAIR

WARNING

The Sidewinder series of IP66/IP67 rated cameras provide a fully sealed, moisture free environment for the internal electronic and mechanical components. If the camera housing cover or seals become compromised due to being struck by objects or damaged during handling, the cameras should be taken out of service IMMEDIATELY, so that the camera can be returned to WTI for repair. This will help prevent further EXPENSIVE internal corrosion damage from occurring. Below are some examples of Damage that will compromise the sealing integrity of the camera.

SAFEGUARDS

IMPORTANT SAFEGUARDS

- 1.) Read Instructions. It is important to read all safety and operating instructions before installing or using this equipment.
- 2.) Retain Instructions. Retain this manual and any supplements for future reference.
- 3.) Follow Instructions. Follow all instructions herein for use of this equipment.
- 4.) Heed all warnings. Adhere to all warnings on the equipment, and in this manual.
- 5.) To reduce the risk of electric shock or equipment damage, work on the unit only when the power is shut off and is unplugged from its power source to prevent accidental activation. Also take precautions to avoid contact between the equipment and other electrical wires or power sources that may be present at the installation site.

GENERAL DESCRIPTION

The Sidewinder SW720-H264-HD is a pan-tilt-zoom camera system that provides high definition color video in a variety of resolutions, up to 1080p30, over an Ethernet connection, using H.264 or MJPEG video compression. The camera provides 360 degree continuous rotation in both the pan and tilt axes, and provides an optical zoom magnification of 20 times or 30 times. A self-cleaning hydrophilic coating is provided on the front lens window of the camera to ensure clear, crisp video images and to reduce maintenance. An electrically conductive Indium-Tin-Oxide coating is provided on the inside of the front lens window to heat it and prevent fogging.

The Sidewinder SW720-H.264-HD camera operates on AC line voltages within a voltage range of 85VAC to 265VAC and an operating frequency of 47Hz to 63Hz. Optional 24VAC power is also available (Side Egress Only). Ethernet 10/100Base-T communication is used for transport of the video and control signals. Power and Ethernet signals are provided via a 36 inch long bottom egress umbilical cable bundle using an outdoor rated SJOOW #18x3 power cable, an outdoor rated shielded CAT-5e Ethernet cable and an RG-59 video cable. The camera umbilical cable is terminated with an 18 Pin MS style male connector or a 16 Pin AMP connector. An optional side egress connector arrangement is also available.

The Sidewinder SW720-H264-HD camera is capable of supporting an H.264 and a second H.264 or MJPEG compressed video stream simultaneously. Support is provided for unicasting and multicasting.

The SW720-H264-HD camera provides Ethernet ports for support of industry standard PTZ control protocols such as Pelco D, COHU, NTCIP, ONVIF and others. Legacy support for physical camera control units can be implemented using serial port to Ethernet converters.

Signals wiring for an RS-485 serial data port and analog NTSC video output are both provided to support upgrading legacy camera installations or for replacing cameras with similar signal interfaces from other manufacturers.

MODELS AND FEATURES

The Sidewinder High Definition IP cameras are available with several signal connector arrangements, two different block cameras, optional electric brakes and optional pressurization. The following table provides a quick reference to the major features available in each camera model.

MODEL	36 INCH MS UMBILICAL	36 INCH AMP UMBILICAL	SIDE EGRESS MS	X20 ZOOM BLOCK CAMERA	X30 ZOOM BLOCK CAMERA	PRESSURIZATION	ELECTRIC BRAKES
SW720-H.264-HD	x			x			
SW720-H.264-HD-ENG	x			x			x
SW720-H.264-HD30	x				x		
SW720-H.264-HD30-ENG	x				x		x
SW720P-H.264-HD	x			x		x	
SW720P-H.264-HD-ENG	x			x		x	x
SW720P-H.264-HD30	x				x	x	
SW720P-H.264-HD30-ENG	x				x	x	x
SW720HV-H.264-HD			x	x			
SW720HV-H.264-HD-ENG			x	x			x
SW720HV-H.264-HD30			x		x		
SW720HV-H.264-HD30-ENG			x		x		x
SW720AMP-H.264-HD		x		x			
SW720AMP-H.264-HD-ENG		x		x			x
SW720AMP-H.264-HD30		x			x		
SW720AMP-H.264-HD30-ENG		x			x		x
SW720-24-H.264-HD			x	x			
SW720-24-H.264-HD30			x		x		
SW720P-24-H.264-HD30			x		x	x	

INSTALLATION

RECOMMENDED TOOLS FOR PROPER INSTALLATION

- 1) Tie wraps to secure cable runs.
- 2) Set of open end wrenches including 7/16" for mounting bolts.
- 3) Cordless power drill for mounting some brackets.
- 4) Safety cable recommended (prevents camera falling during overhead installations).
- 5) Self-sealing connector tape to weatherproof all cable connections.

INSTALLATION PLANNING

- 1) The maximum cable length that should be planned for is 100 meters, based on the limit for 10/100Base-T Ethernet connections.
- 2) The Sidewinder SW720-H264-HD camera draws up to 50 Watts maximum, which translates to about 0.59 Amps at the low line voltage limit of 85VAC.
- 3) Be sure to verify that there are no physical obstructions that might prevent the camera from turning freely in all directions.
- 4) Be sure to verify that there are no physical obstructions in the way of any required viewing directions.
- 5) Be sure that there is access to the end of the umbilical cable on the bottom of the camera to facilitate connecting and disconnecting the camera while it is in place on the mounting bracket or pole.

UNPACKING

Please examine the equipment carefully when unpacking the shipping container. If any damage is noted please be sure to file a claim with the carrier. WTI is not responsible for any damage that occurs during shipping. Please verify that all of the contents are present and carefully check the packing material for any loose items before recycling it.

EQUIPMENT SUPPLIED WITH UNIT

- 1.) Camera
- 2.) 4 each 1/4-20 x 3/4" mounting screws with washers
- 3.) Quick Start Manual

EQUIPMENT THAT MAY BE REQUIRED, BUT NOT SUPPLIED WITH UNIT

- 1.) Mating connector and strain relief for umbilical extension cable
- 2.) Camera mounting bracket
- 3.) Interconnect cables
- 4.) Video monitor
- 5.) PC or laptop computer
- 6.) Setup software

DIMENSIONS AND MOUNTING

MECHANICAL DIMENSIONS

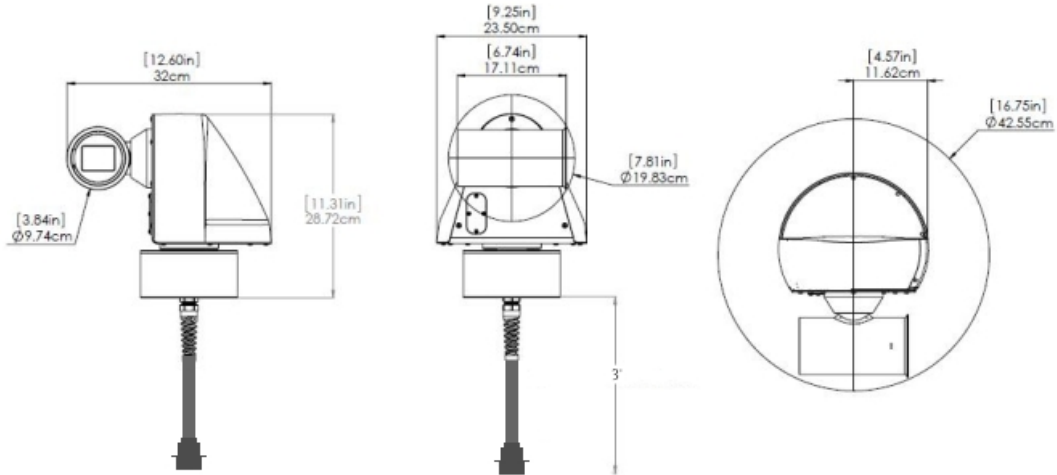

BOTTOM EGRESS

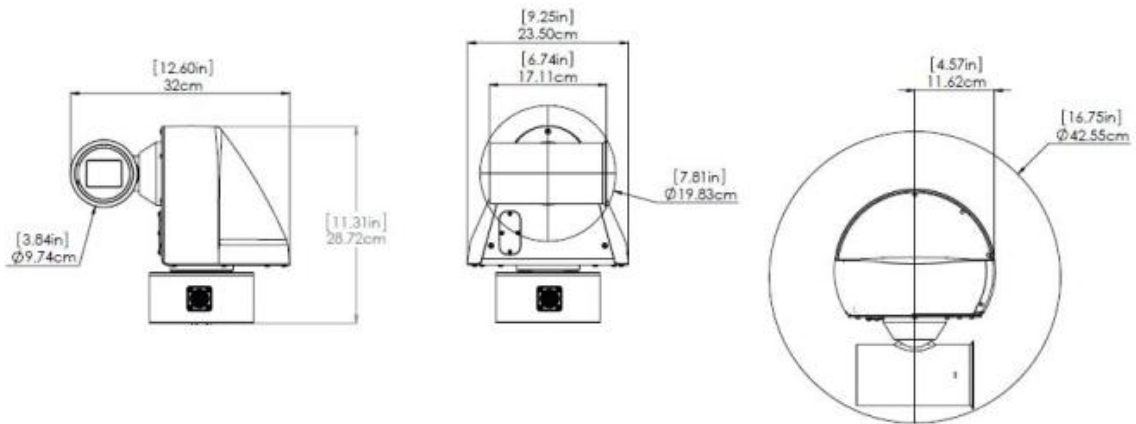

SIDE EGRESS

MOUNTING

The Sidewinder SW720-H264-HD camera should normally be mounted in an upright orientation, as shown above. The camera may also be mounted upside down if desired, but a cover of some sort should be placed over the bottom of the camera, extending out to about 6 inches past the camera all around, to prevent debris, dirt or snow and ice from accumulating on the bottom of the camera housing, since the conical shaped profile of the camera will no longer be able to naturally shed material to the sides. The camera may NOT be mounted with the base facing horizontally.

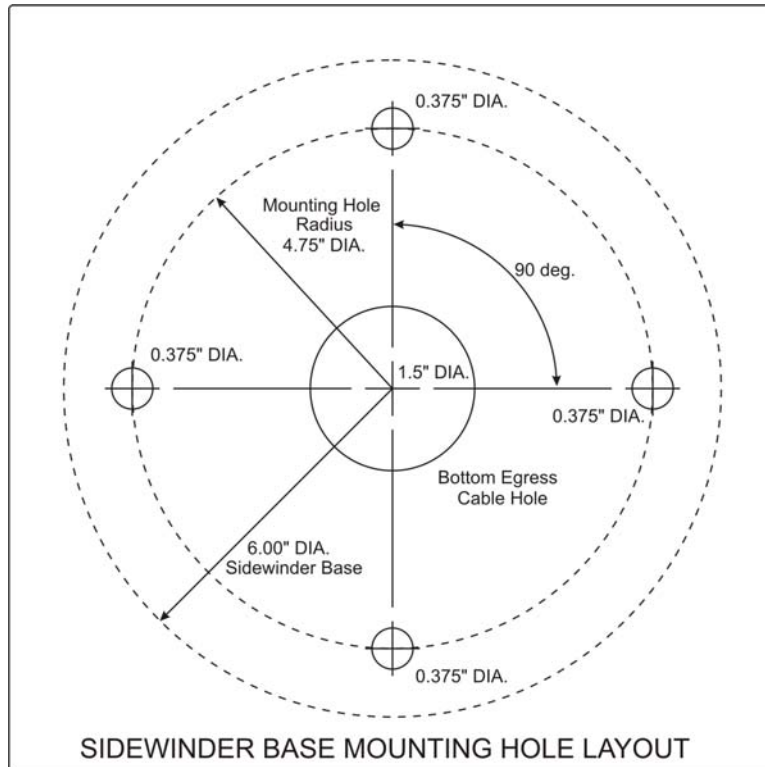

The base of the Sidewinder SW720-H.264-HD camera has four 1/4-20 screw holes that are equally spaced, 90 degrees apart, on a 4.75" diameter circle, as shown in figure 2 (Note that 24VAC versions of the Sidewinder camera will have 5/16" mounting screws). If mounting screws other than those provided with the camera are used, the length of the mounting screws should be selected so that the screws penetrate no more than 0.75 inches into the base.

MOUNTING ACCESSORIES

WTI manufactures several different mounts for the Sidewinder SW720A that allow the camera to be attached to pole tops, horizontal poles, vertical poles and walls. The Sidewinder SW720-H.264-HD camera is supplied with a 36 inch umbilical cable to allow the cable to be routed through the camera mount before the actual physical installation of the camera.

SWWM1 – Wall Mount Option

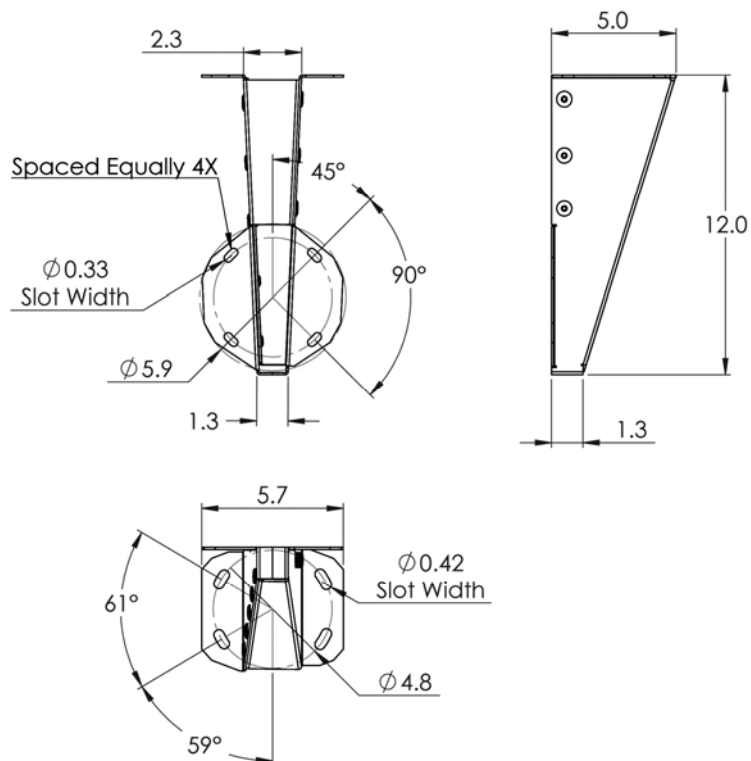
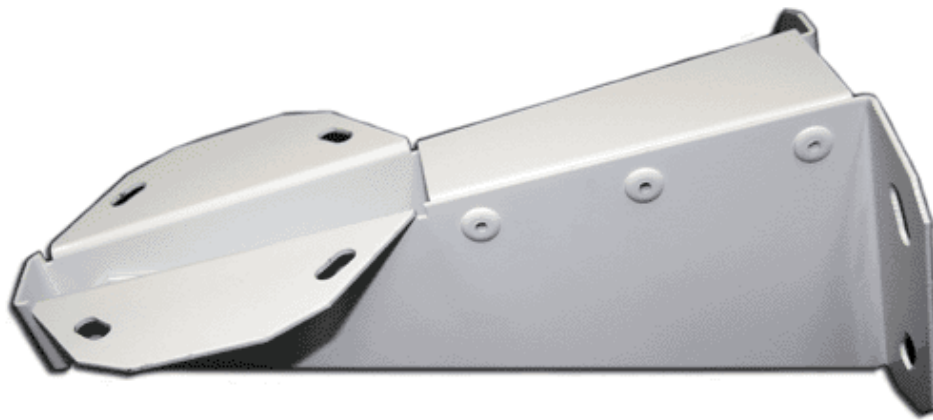

SWWM1 + SWVPA – Wall Mount with Vertical Pole Adapter

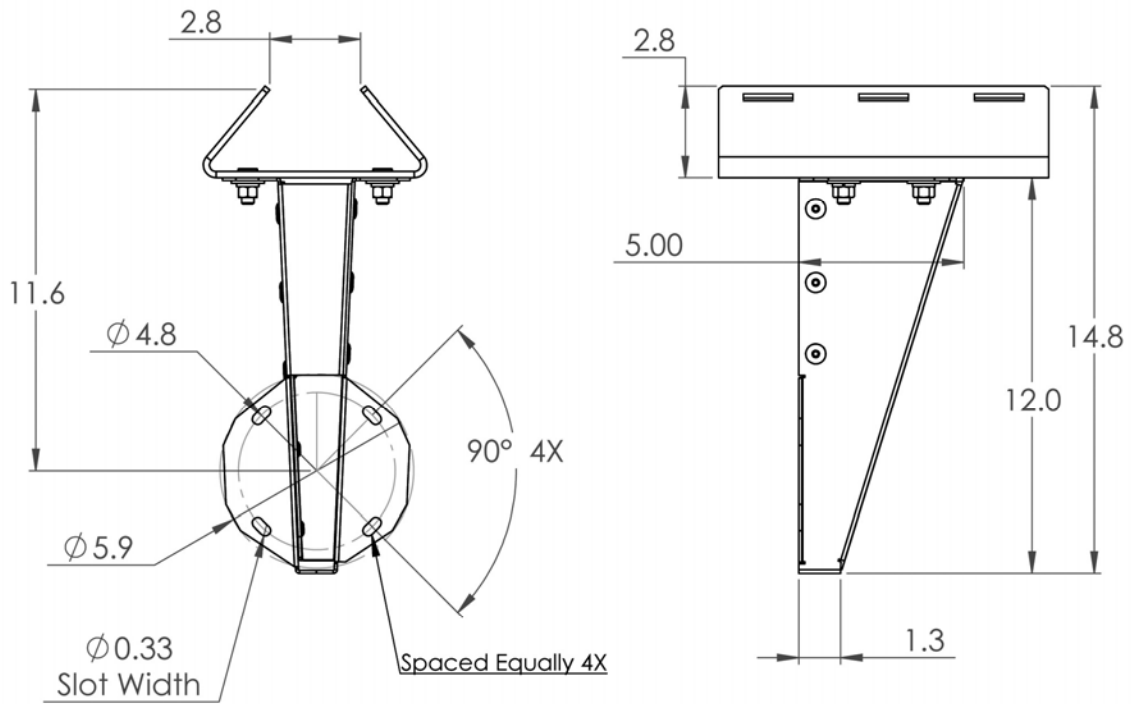

Units = Inches

SWPTM1 – Pole Top Mount

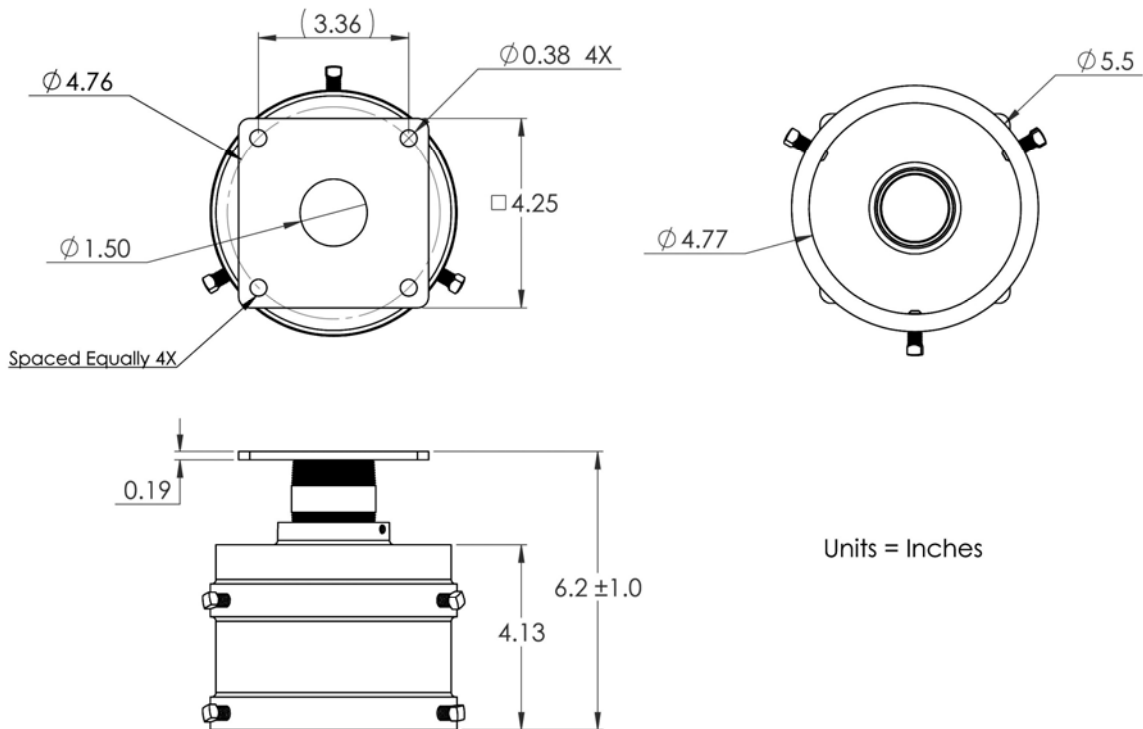

SWHPM1 – Horizontal Pole Mount

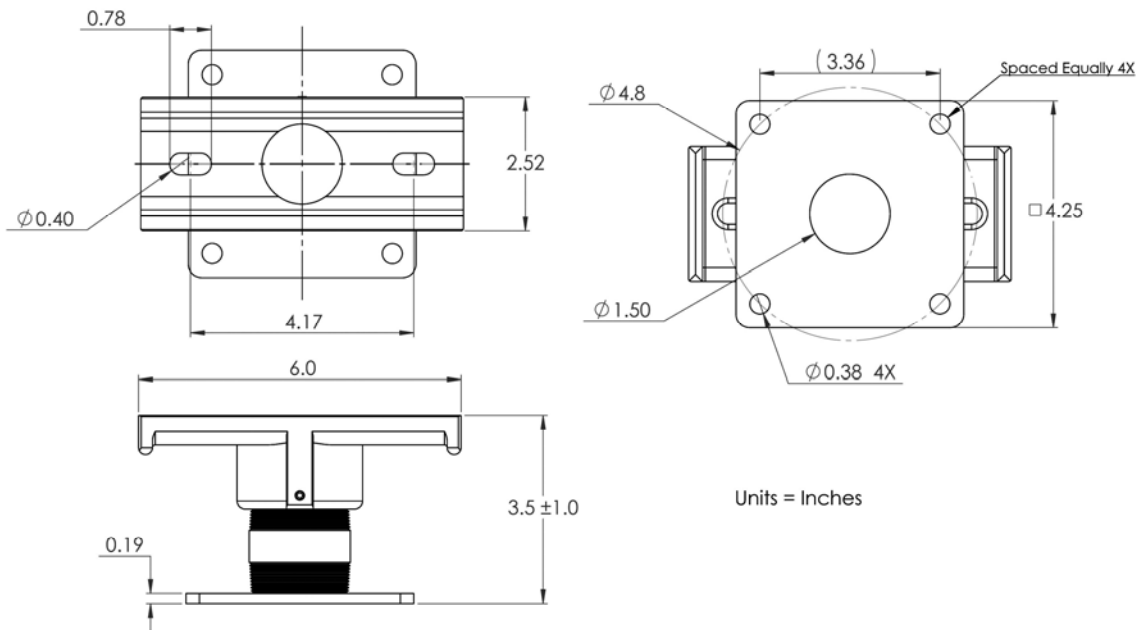
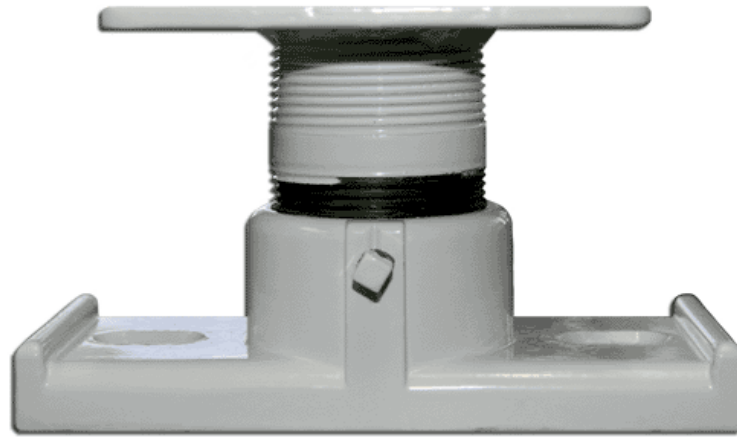

15-4-1430 – 6"x6"x3/8" Square Mounting Plate

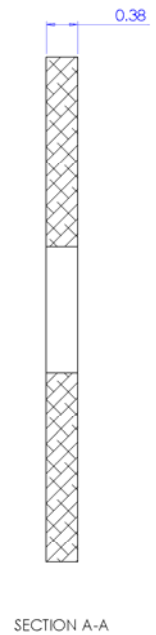
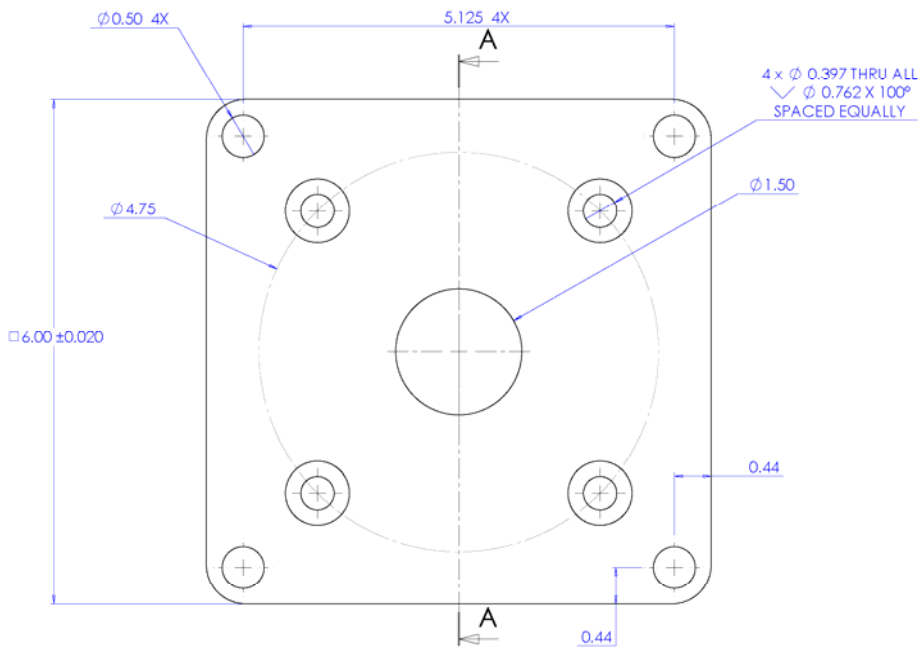

15-4-913 – 6”Round Riser Mounting Base

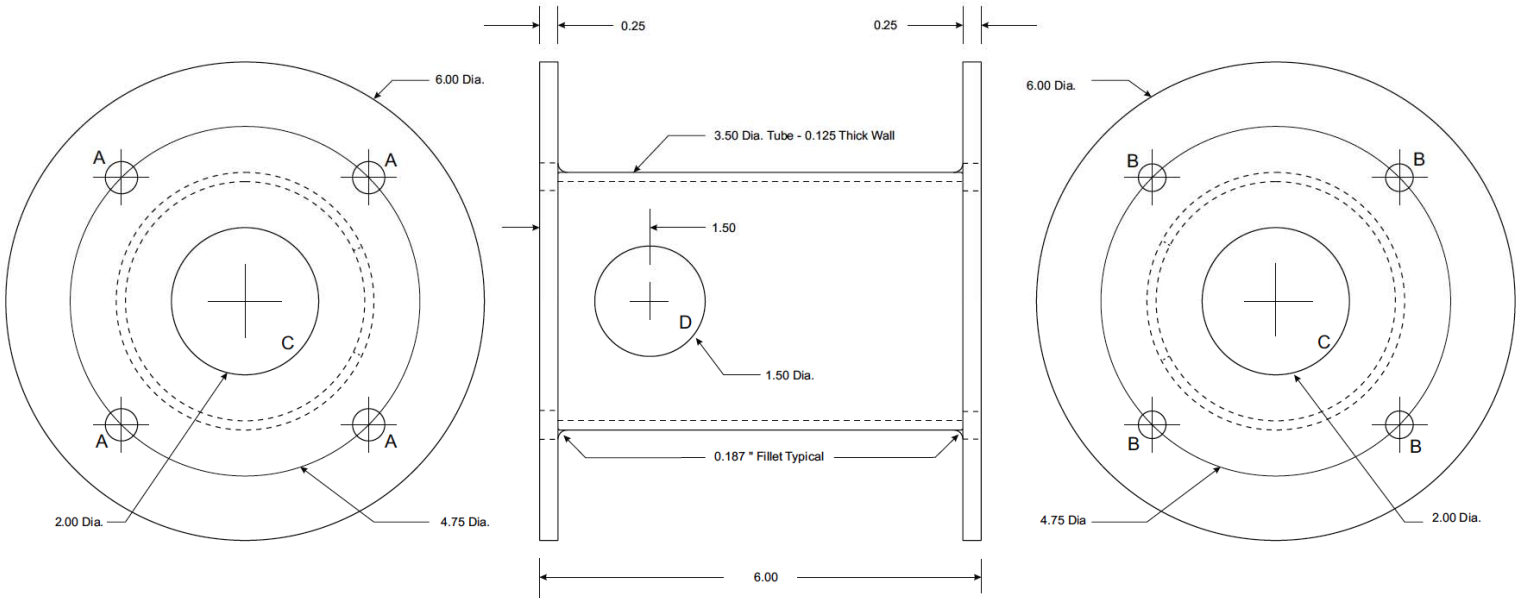

120VAC MS SIGNAL CONNECTIONS

The Sidewinder SW720-H.264-HD is provided with a 36 inch umbilical cable and is available with an 18 pin MS Style connector at the end. The umbilical cable provides the power and Ethernet data and control signals for the camera. The umbilical cable exits through the bottom of the camera housing. These connector pin outs are for all SW720-H.264-HD models except for 24VAC and AMP connector models.

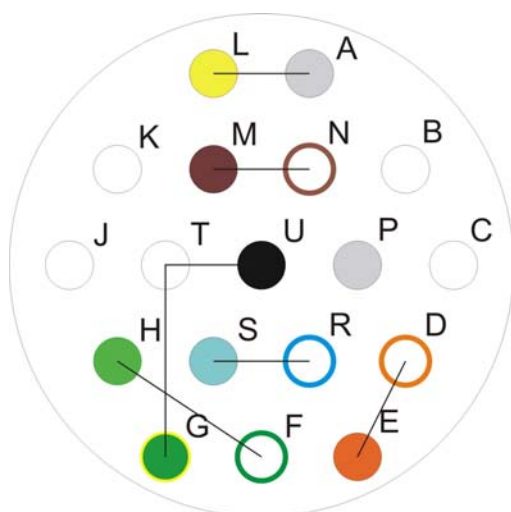

Mating Connector

Female MS Connector - Style MIL-DTL-26482
Amphenol P/N MS3116F-14-18S
Shell Size 14 - 18 Contact Pattern

PIN	<i>Signal Description</i>	<i>Wiring Color Code and Wire Recommendations</i>
A	Analog Video Shield	RG-59U Shield
B		
C		
D	Ethernet Tx+	Orange/White CAT-5e
E	Ethernet Tx-	Orange CAT-5e
F	Ethernet Rx+	Green/White CAT-5e
G	AC Safety Ground	SJOOW Green (18 AWG)
H	Ethernet Rx-	Green CAT-5e
J		
K		
L	Analog Video Output	RG-59U Center
M	RS-422 RX +	Brown CAT-5e
N	RS-422 RX -	Brown/White CAT-5e
P	RS-422 Data Shield	CAT-5e Shield (Belden 1300A)
R	RS-422 TX -	Blue/White CAT-5e
S	RS-422 TX +	Blue CAT-5e
T	AC Line Neutral (low)	SJOOW White (18 AWG)
U	85-265 AC Line Input (high/hot)	SJOOW Black (18 AWG)

24 VAC MS STYLE SIGNAL CONNECTIONS

SW720-24-H.264-HD - Side egress 18 Pin MS style connector

SW720-24-H.264-HD30 - Side egress 18 Pin MS style connector

SW720P-24-H.264-HD30 - Side egress 18 Pin MS style connector

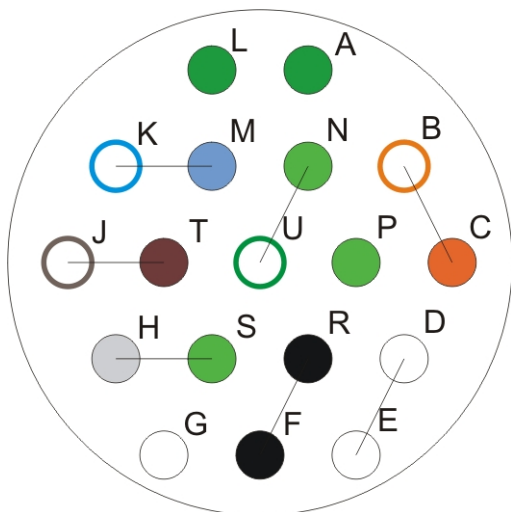

Mating Connector

Female MS Connector - Style MIL-DTL-26482

Amphenol P/N MS3116F-14-18S

Shell Size 14 - 18 Contact Pattern

PIN	<i>Signal Description</i>	<i>Wiring Color Code and Wire Recommendations</i>
A	Chassis Ground	Overall Shield Drain Wire
B	Ethernet TX+	CAT-5 Orange/White
C	Ethernet TX-	CAT-5 Orange
D	24 VAC - 1	White 20 AWG Minimum
E	24 VAC - 1	White 20 AWG Minimum
F	24 VAC - 2	Black 20 AWG Minimum
G		
H	Analog Video Shield	RG-59U Shield
J	RS-422/485 Rx-	CAT-5 Brown/White
K	RS-422/485Tx-	CAT-5 Blue/White
L	Data Ground	Data Cable Shield
M	RS-422/485 Tx+	CAT-5 Blue
N	Ethernet RX-	CAT-5 Green
P	AC Safety Ground	Green 20 AWG Minimum
R	24 VAC - 2	Black 20 AWG Minimum
S	Analog Video Output	RG-59U Center
T	RS-422/485 Rx+	CAT-5 Brown
U	Ethernet RX+	CAT-5 Green/White

120VAC AMP STYLE SIGNAL CONNECTIONS

SW720AMP-H.264-SD - 36 inch umbilical cable with a 16 pin AMP style connector

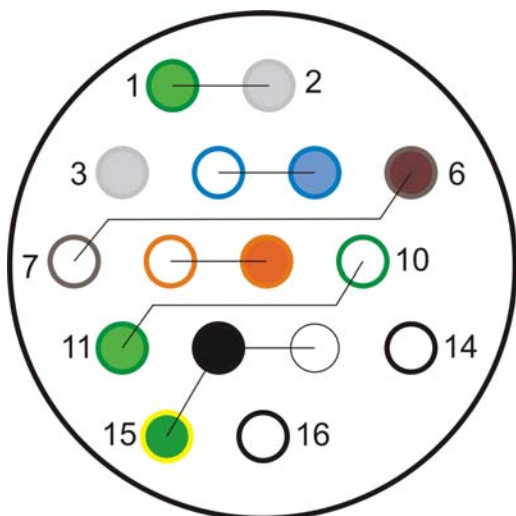

Mating Connector

AMP Connector - P/N 206037-1

Clamp – P/N 1310307

16 Contact Pattern

Female Pins – 3 each – P/N 66565-4 - #20-24

Female Pins – 12 each – P/N 66109-4 - #24-26

PIN	<i>Signal Description</i>	<i>Wiring Color Code and Gauge Recommendations</i>
1	Analog Video Output	RG-59U Center
2	Analog Video Shield	RG-59U Shield
3	Data Ground	Cat-5e Data Cable Shield
4	RS-485 Tx-	CAT-5e Blue/White
5	RS-485 Tx+	CAT-5e Blue
6	RS-485 Rx+	CAT-5e Brown
7	RS-485 Rx-	CAT-5e Brown/White
8	Ethernet TX+	CAT-5e Orange/White
9	Ethernet TX-	CAT-5e Orange
10	Ethernet RX+	CAT-5e Green/White
11	Ethernet RX-	CAT-5e Green
12	85-265 AC Line Hot	SJOOW Black (18 AWG)
13	AC Line Neutral	SJOOW White (18 AWG)
14	spare	
15	115 VAC Safety Ground	SJOOW Green (18 AWG)
16	Spare	

SIGNAL DESCRIPTIONS

120VAC LINE CONNECTIONS

The AC Line connections should be connected to an AC mains source with a voltage of 85VAC to 265V AC, operating at a frequency of 47Hz to 63Hz. The nominal operating voltage is normally 115VAC or 230VAC. The camera draws 50 Watts maximum, which translates to about 0.6 Amps at the worst case low line voltage of 85VAC. We recommend SJOOW cable for these signals.

24VAC POWER CONNECTIONS

The 24VAC power connections require the use of heavier gauge wiring and shorter cable lengths than the 120VAC power option, as the 24VAC camera model draws approximately 5 times as much current through the cable wiring, due to the reduced operating voltage. Four power connection terminals are provided on the MS connector to allow paralleled power wiring. Cable runs of up to 150 feet require paralleled #20 AWG wiring (equivalent to #17 AWG) for reliable operation. Longer runs should use correspondingly larger wire gauges to minimize voltage drop along the cables. Runs of 300 feet can use #14 AWG wiring and runs of 500 feet can use #10 AWG or #12 AWG wiring.

ETHERNET SIGNAL CONNECTIONS

The Ethernet signals should be connected using a CAT-5e or CAT-6 cable. If the legacy serial data control port is to be used, the Ethernet cable should be the shielded type and the Ethernet cable shield should be connected to the data shield signal. We recommend Belden 1300A cable for these signals.

ANALOG VIDEO CONNECTIONS

An NTSC standard definition video signal output provides a 1Vpp NTSC video signal with a 75 Ohm drive impedance. We recommend Belden 9259 RG-59/U cable.

HARD WIRED PTZ SERIAL CONTROL PORT

A secondary hard wired RS-485 port is provided on the SW720-H264-SD camera for PTZ and other camera control functions. These signals can be conveniently accessed at the cabinet end of the customer installed control cable by using the WTI RJ-45 Serial Data Breakout Box.

There are internal 120 Ohm termination resistors for both the TX and RX signal pairs. The factory shipped default state for the 120 Ohm terminations is for both the TX and RX terminations to be enabled. Applications that involve multiple cameras on the same RS-485 communications lines will require that the terminations on all cameras but one be turned off.

RJ-45 SERIAL DATA BREAKOUT BOX

An RJ-45 Serial Data Breakout Box is available to facilitate legacy installations that utilize the RS-485 signals available on the SW720-H.264-HD series of cameras. The RS-485 signals are routed on the two unused pairs in the Ethernet CAT-5e or CAT-6 cable. Note that shielded Ethernet CAT-5e or CAT-6 cable, like Belden 1300A, should be used for these types of legacy installations. The breakout box is wired into the system at the cabinet end of the Ethernet cable on the RJ-45 Ethernet plug. An input RJ-45 and Output RJ-45 connector are provided on the breakout box for passing through the Ethernet data, and a 5 Pin Phoenix style connector interface is provided for extracting the RS-485 signals from the Ethernet cable..

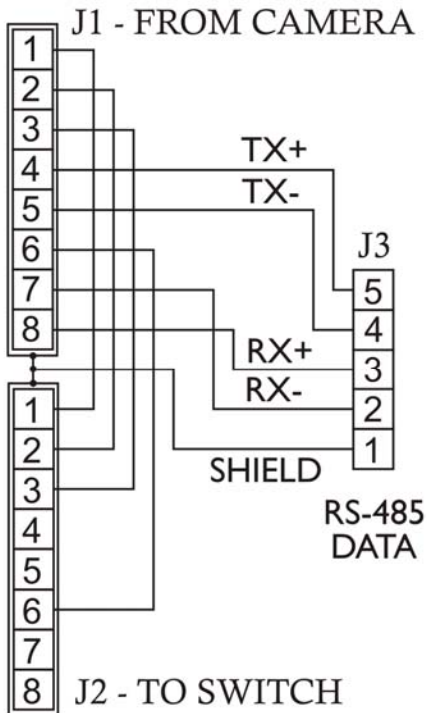
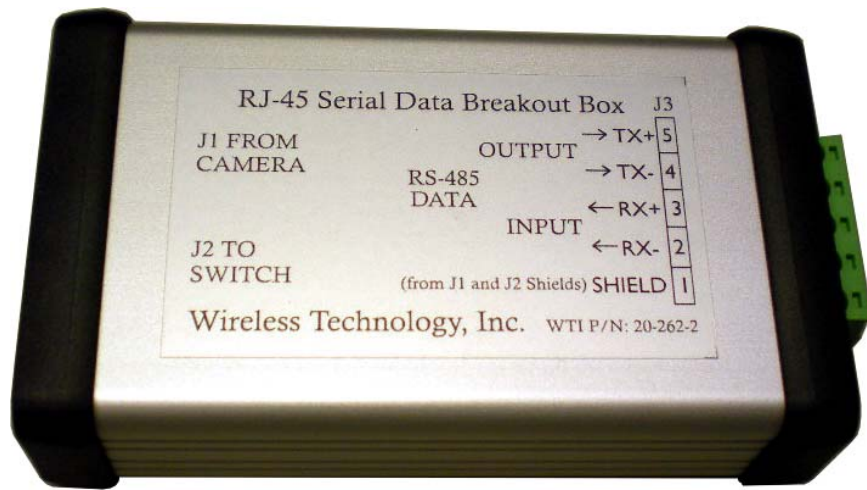

CAMERA ETHERNET PROTOCOLS AND PORTS

The PTZ camera control functions and video streaming functions to and from the SW720-H264-SD camera are transmitted over a 100Base-TX Ethernet connection using specific Ethernet ports are assigned for each of the various functions and protocols.

DEFAULT IP ADDRESS

The SW720-H264-SD camera default IP Address is: **192.168.1.251**

DEFAULT PORT ADDRESSES

The following ports are provided for the various services available.

Protocol	Default Port	Default Transport	Notes
WTI	53935	UDP	
NTCIP	55000	UDP	
Pelco-D	55001	UDP	Sidewinder H.264 series devices are fixed at multidrop address 1.
Cohu	55002	UDP	Sidewinder H.264 series devices are fixed at multidrop address 1.
ONVIF	55003	TCP	UDP not supported. Server shared with HTTP by default.
HTTP Server	55003	TCP	UDP not supported. Server shared with ONVIF by default.
Pass-Through	55004	UDP	Disabled by default on Sidewinder SW720 H.264 SD/HD. Enabled by default on Sidewinder H.264 Video Encoder.
WS-Discovery	3702	UDP Multicast (group address 239.255.255.250)	
RTSP Server	8554	TCP	UDP not supported
Multicast Video RTP/RTCP	18888/18889	UDP Multicast (group address	Only if video stream 1 is set up for Multicast transport. A

Protocol	Default Port	Default Transport	Notes
(Stream 1)		random SSM)	static group address may also be configured.
Multicast Video RTP/RTCP (Stream 2)	18890/18891	UDP Multicast (group address random SSM)	Only if video stream 2 is set up for Multicast transport. A static group address may also be configured.

CAMERA PROTOCOL SUPPORT

The SW720-H264-SD camera supports COHU, Pelco D, WTI, NTCIP, Web/ONVIF and other protocols through the RS-485 data connections. The RS-485 serial port can be configured using the On Screen Menu system or by using the WTI Camera Control GUI program through the Ethernet connection.

The various protocols can also be accessed through the use of different port numbers when sending camera control commands to the Sidewinder using an Ethernet connection.

COHU Protocol: 55002
Pelco D Protocol: 55001
WTI Protocol: 53935
NTCIP Protocol: 55000
Web/ONVIF Protocol: 55003

As long as they are not used simultaneously, it is possible to use multiple different protocols from different control stations when using the Ethernet protocol support. For example, if COHU protocol is being used locally on the RS-485 serial data port, it is possible to use NTCIP protocol over the Ethernet from the head end monitoring center to control the camera on port 55000.

SURGE PROTECTION AND PRESSURIZATION

SURGE PROTECTION

The SW720-H264-HD camera provides internal surge protection for all of the power, data and video signals.

- 1.) The AC line power connections are provided with 275 volt 135 Joule MOV surge arrestors rated for 6000 Amp pulses. A 3A SMT fuse is included in the primary circuit to prevent catastrophic printed circuit board damage in the case of gross AC line input overloads.
- 2.) The video signal lines incorporate a two stage protection circuit consisting of a primary 90V gas discharge tube, followed by a high speed, low capacitance 6.2V 2kW peak power transient voltage suppressor.
- 3.) The data signal lines incorporate a two stage protection circuit consisting of a primary 90V gas discharge tube, followed by an 18V, 300W, 40A transient voltage suppressor.

SEALING AND PRESSURIZATION

The SW720-H264-HD camera provides two levels of sealing and pressurization. The entire camera, including the base, housing and camera tube are all sealed to IP66/67 levels to prevent any ingress of dust or moisture. An additional option is available, in which the camera housing tube is pressurized to 5 psi with dry nitrogen gas.



The SW720-H264-HD camera with the pressurization option is provided with a Schrader valve to allow periodic replenishment of the dry Nitrogen in the camera housing tube. Since no sealing system will remain 100% airtight indefinitely, it may be necessary to replenish the dry Nitrogen occasionally. This can be done at the same time that the regular camera cleaning is performed. A 15psi pressure relief safety valve is provided to prevent damage to the seals and to prevent blowing out the front or back plates of the camera housing if an unregulated high pressure dry Nitrogen tank were to be connected to the Schrader valve.

SPECIFICATIONS

X30 ZOOM IMAGE SENSOR AND LENS

Image Sensor Type	Solid State EXMOR CMOS Progressive Scan
Image Sensor Size	1/2.8" inch type
Pixel Resolution	2144 horizontal x 1588 vertical (total) – 2096(H) x 1561(V) viewable
Video Output Format HD:	1080P30 at full resolution
Maximum Lens Aperture	F1.6 at full wide angle – F4.7 at full telephoto
Optical Zoom Range	x1 to x30
Focal Length	4.3mm ~ 129mm
Digital Zoom Range	x1 to x12 with smooth transition from optical to digital
Combined Focal Length	4.3mm ~ 1548mm
Optical Zoom Speed	0.8sec
Horizontal Angle of View	63.7 degrees (wide angle) to 2.3 degrees (tele)
Minimum Focus Distance	0.4 inches (wide angle) to 40 inches (tele)
Electronic Stabilization	10Hz
Auto Focus	Selectable between Auto/Manual
Manual Focus Speed	3.2sec Tracking Off – 4.6sec Tracking On
Shutter Speed	Adjustable from 1 second to 1/10,000 second. Settings below 1/60 second increase integration time to improve low light sensitivity with video frame store to provide continuous video output.
Auto Iris	16 Steps
AGC Range	0dB to 28dB – 1dB steps
Minimum Illumination	0.35lux (1/30sec,50IRE, High SENS.)
Color Balance	AUTO, ATW, Indoor, Outdoor, OnePush WB, Manual WB, Outdoor Auto, Sodium Vapor Lamp.
Gamma	Normal, Straight
Signal to Noise Ratio	>50dB
Synchronization	Crystal
Features	EIS, De-Fog, Visibility Enhancement, Noise Reduction, Backlight Compensation, High Sensitivity Mode, Color Enhancement, Stable Zoom, IR Cut Filter, Wide Dynamic Range

X20 ZOOM IMAGE SENSOR AND LENS

Image Sensor Type	Solid State EXMOR CMOS Progressive Scan
Image Sensor Size	1/2.8" inch type
Pixel Resolution	2144 horizontal x 1588 vertical (total) – 2096(H) x 1561(V) viewable
Video Output Format HD:	1080P30 at full resolution
Maximum Lens Aperture	F1.6 at full wide angle – F3.5 at full telephoto
Optical Zoom Range	x1 to x20
Focal Length	4.7mm ~ 94mm

Digital Zoom Range	x1 to x12 with smooth transition from optical to digital
Combined Focal Length	4.7mm ~ 1128mm
Optical Zoom Speed	0.8sec
Horizontal Angle of View	55.4 degrees (wide angle) to 2.9 degrees (tele)
Minimum Focus Distance	0.4 inches (wide angle) to 40 inches (tele)
Electronic Stabilization	None
Auto Focus	Selectable between Auto/Manual
Manual Focus Speed	1.6sec Tracking Off – 2.3sec Tracking On
Shutter Speed	Adjustable from 1 second to 1/10,000 second. Settings below 1/60 second increase integration time to improve low light sensitivity with video frame store to provide continuous video output.
Auto Iris	16 Steps
AGC Range	-3dB to 28dB – 16 steps
Minimum Illumination	0.5lux (1/30sec,50IRE, High SENS.
Color Balance	AUTO, ATW, Indoor, Outdoor, OnePush WB, Manual WB, Outdoor Auto, Sodium Vapor Lamp.
Gamma	Normal, Straight
Signal to Noise Ratio	>50dB
Synchronization	Crystal
Features	Noise Reduction, Backlight Compensation, High Sensitivity Mode, Color Enhancement, IR Cut Filter, Wide Dynamic Range

VIDEO ENCODING

Video Encoding	H.264 (Baseline, Main, High Profiles, up to Level 4), MJPEG and MPEG-4 standards
Video Streams	Two independently configurable streams; (2) H.264 streams or (1) H.264 and (1) MJPEG or (1) MPEG-4 and (1) MJPEG
Codec	Video Stream 1: H.264 or MPEG-4 Video Stream 2: H.264 or MJPEG
Image Resolution	1080p, 720p, D1, VGA, 2CIF, HVGA, QVGA
Streaming Mode	CBR or VBR
Image Settings	GOP (M, N), Quality Value, Slice Mode
Frame Rate	30, 15, 7, 4, 2, 1, (M, N)
Data Rate	Adjustable from 64k to 12 Mbps in VBR mode and 64k to 16 Mbps in CBR mode.
Connection Types	Unicast, multi-unicast or multi-cast
Video Latency	<250ms
Network Protocol Layers	RTP, RTSP, UDP, TCP, IP, HTTP, IGMPv2, ICMP, ARP as a minimum

CAMERA HOUSING MODULE

External Window Coating	High temperature vacuum deposited hydrophilic coating to reduce window cleaning maintenance.
Internal Window Coating	Electrically conductive coating to allow energy saving direct heating of window glass to prevent fogging.
Window Heat Control	Proportionally controlled closed loop window heater drive circuit with outside temperature sensor unit to provide fog free window operation under all environmental conditions.
Block Camera Heating	Temperature sensor and microprocessor controlled image sensor heater to provide reliable operation of zoom lens down to -34 degrees Celsius.

PAN AND TILT DRIVE ASSEMBLIES

Drive Range	360 degrees continuous rotation (both axes)
Drive Speed	Variable from 0.0003 Deg/Sec to 100 Deg/Sec
Drive Resolution	0.005625 Degrees
Drive Repeatability	0.05 Degrees typical
Preset to Preset Time	Selectable between 2 seconds and 5 seconds for 180 degree motion in both axes
Operator Motion Speed	Pan and Tilt speeds are proportional to both operator speed commands and camera zoom setting.
Brakes	Optional electrically operated pan and tilt motor brakes with a minimum holding torque of 300 oz./in available to maintain the camera position when power is removed from the camera.
Presets	Minimum of 64 presets, each preset to store variable data for pan position, tilt position, zoom setting, focus setting and 24 characters of titling text to be displayed when the preset is recalled. Preset titling to remain on screen until subsequent preset or camera control commands are received.
Tours	Eight tours of up to 32 presets each shall be supported. Presets may be assigned to the tours in any order and may be used multiple times within one tour.
Panning Tours	Any or all of the eight tours may be used as “panning” tours by selecting exactly two presets for the tour. The first preset selected for the tour shall set the counter-clockwise panning limit and the tilt angle for the tour, and the second preset selected shall set the clockwise panning limit for the tour. The positioning system shall pan smoothly from one preset to the other and back again until a subsequent camera command is received.

Sector Zones	Up to 16 sector zones with user settable right and left pan limits may be programmed with one line of up to 20 characters of ID titling per zone.
Privacy Zones	Any Sector Zone may be utilized as a privacy zone by setting the video mode to “OFF” within that zone.
Low Pressure Warning	Provides low pressure warning indicator on video display for cameras supplied with pressurized camera housing option.
Temperature Warning	Provides an internal temperature warning indication on the video display.
Program Memory	Unit is field upgradable using FLASH non-volatile memory to store programming.

ELECTRICAL

AC Line Voltage	85-265 VAC 50/60 Hz
Power Consumption	<50W with all options operating
Analog Video Output	75 Ohm, 1Vpp, NTSC, EIA-170A
Video Transient Protection	Gas discharge tube followed by 40A 2kW transient voltage suppressor.
Control Data	EIA RS-485 signal levels and drive capabilities.
Data Transient Protection	Gas discharge tubes followed by 40A 300W transient voltage suppressors.
Control Data Protocol	Cohu, Pelco D, WTI, NTCIP, ONVIF and others
Power interrupt immunity	NEMA TS-2 paragraph 2.1.4.
Power transient immunity	NEMA TS-2 paragraph 2.1.6.
Interface connector	MS style 18 Pin weatherproof and corrosion resistant type with gold plated contacts or AMP style 16 pin type with gold plated contacts.

ENVIRONMENTAL

Ambient Temp. Limit	-29° F to +165° F (-34° C to +74° C) (Conforms to NEMA TS-2 paragraphs 2.1.2, 2.1.3 and 2.1.5.)
Humidity	100% relative humidity
Protection Rating	IP-67/NEMA-4X/ASTM-B117 (entire camera)
Air Contaminants	Withstands exposure to sand, dust, fungus, salt atmosphere, per MIL-E-5400T, paragraph 3.2.24.7, 3.2.24.8, and 3.2.24.9
Vibration	NEMA TS-2 paragraphs 2.1.9 and 2.2.3 using a 0.5g amplitude signal from 5Hz to 30Hz applied in each of 3 mutually perpendicular axes for 30 minutes.
Shock	NEMA TS-2 paragraphs 2.1.10 and 2.2.4 using a 10g amplitude, 10ms duration shock pulse in each of three mutually perpendicular axes.
Water Spray Immunity	IPx6 rating - IEC 60529 section 14.2.6 using a 25 gallon per minute water stream through a 12.5mm nozzle at nine feet for three minutes.

Water Immersion Immunity	IPx7 - IEC 60529 section 14.2.7 using an immersion depth of 1 meter measured at the bottom of the camera and a duration of 30 minutes.
Icing Immunity	NEMA 250-2003 section 5.6.
Corrosion Immunity	NEMA 250-2003 section 5.10 and the procedure specified in ASTM-B117 Marine.
EMI Radiation	Within the limits set by FCC Regulations 47 CFR Part 15 for Class A devices.

MECHANICAL

Dimensions	12.6”L x 11.3”H x 9.25”W (32cm x 29cm x 20cm)
Weight	14.6 lbs. (6.64 kg.)
Construction	White powder coated aluminum and Kydex 550 with all stainless steel hardware

REVISION HISTORY

01/15 – Update: Video Encoding Section
 Added: IP66/IP 67 Broken Seal Warning

12/14 – Changed logo

11/14 – Add: Additional mounting options

6/14 – Added: Specification section at end of document, multiple model numbers to title page, model feature matrix, AMP connector pin outs, RJ-45 Breakout Box, 24VAC wiring diagrams, Ethernet address and port data.

11/13 – Analog video and RS-485 signal wiring in MS umbilical connector wiring chart changed to standard, rather than optional. Mechanical dimensions drawing modified to show umbilical connector with standard 3 foot length, rather than AC Plug and RJ-45 Connector.